

Creating Intelligent Computer Workstation of a Freight Officer in a Single Information Space of Railway Transport: Synergetic Approach

Saken K. Malybaev^a, Nurlan S. Malaybaev^a, Botakoz M. Isina^a, Akbope R. Kenzhekeeva^a and Nurbol Khuangan^a

^aKaraganda State Technical University, Karaganda, KAZAKHSTAN.

ABSTRACT

The article presents the results of researches aimed at the creation of automated workplaces for railway transport specialists with the help of intelligent information systems. The analysis of tendencies of information technologies development in the transport network was conducted. It was determined that the most effective approach is to create an information transport architecture, together with the quality management system of transport services. Automated workplace for specialists of rail transport with this approach is synergistically formed as a local information space and process automation as part of a single intelligent information transport space in accordance with the strategy of transport development, management and information technologies. This approach allows standardizing technological processes of traffic, identifying points of risk of occurrence of security threats and information loss, forming a dynamic information environment decision support. The main problems of the effective operation of intelligent transport systems in general and each automated sites are information security, reliability of information, the stability of data transmission systems, and qualification of the personnel. The basis for the formation of local computer workstations are optional models of technological processes, taking into account the large number of situations on the railway transport options. The paper presents an example of modeling operations and assessment of the costs of the working time of commodity cashier. An analysis found fotochronometry the most appropriate for the study, which serves as the basis for action photography worker per shift with simultaneous maintenance of chronometry observations lasting one or another of his actions. The mathematical apparatus of research, calculation and optimization of logical systems is a simulation pertaining to the theory of probability, mathematical statistics and represented in terms of queuing theory. The proposed changes to modernize the automated place for commercial cashier can be embedded in the enterprises of the railway of Kazakhstan.

KEYWORDS

rail transport, intelligent transport systems, automated workstation, information security, Republic of Kazakhstan

ARTICLE HISTORY

Received 7 March 2016
Revised 22 June 2016
Accepted 11 July 2016

CORRESPONDENCE Botakoz M. Isina ✉ bota_kazatk@mail.ru

© 2016 Malybaev et al. Open Access terms of the Creative Commons Attribution 4.0 International License (<http://creativecommons.org/licenses/by/4.0/>) apply. The license permits unrestricted use, distribution, and reproduction in any medium, on the condition that users give exact credit to the original author(s) and the source, provide a link to the Creative Commons license, and indicate if they made any changes.

Introduction

Considering the geographic characteristics and low population density, the development of Kazakhstan's economy is largely determined by the development of the railway industry. The growing need of the industry and population for transport nodes, the increasing mobility of the population and business, and the desire to improve the living standard and increase employment necessitate the development of transport services (Smith & Zhou, 2014; Kim & Van Wee, 2011; Berikbayev & Isina, 2005) and the improvement of their organization and information support (Rosová, Balog & Šimeková, 2013; SAP AG, 2014).

In order to prevent rail transport failures that can cause not only financial and physical damage, but also serious accidents, it is necessary to minimize the human factor, i.e. to create an intelligent automated workstation (AW) (Huang et al., 2015; Balog et al., 2015).

Thus, this paper focuses on general trends and conceptual approaches of development of the complex automated railway system and gives a detailed example of upgrading computer workstation of a freight officer for the implementation of targeted operations and monitoring of an end-to-end automated transportation process.

Literature Review

The development of high-speed rail transport involves the creation of various methods and models: the two-level method for optimizing the arrangement of railway freight center stations and organizing the carriage traffic (UNECE, 2012), operative methods for studying the optimization of rail transportation (Agarana, Anake & Okagbue, 2016), methods for optimizing and integrating railway freight stations, based on a hybrid neural network model (Sun, Lang & Wang, 2014), a synthetic optimization model for freight rail transportation (Xing-cai et al. 2014).

Practical experience of computer workstation development in railways of different countries speaks of the active introduction of computer workstations (Timofeev, 2015; Overby, 2016; Hitachi Dta Systems, 2012; SAP AG, 2014). Thus, for example, Slovakia started introduction of end-to-end electronic railway bills (Balog et al., 2015). The report of the Lithuanian Railways also focused on the automation of transportation processes (Lietuvos Geležinkeliai, 2014).

However, practitioners believe that some processes stay non-automated, or the software which is not integrated into the complete unit is used (Banister & Stead, 2004). Local design of computer workstations, the lack of general compositional scheme of automation of logistical chains in transport can lead to inefficient use of information technology (Rabah & Mahmassani, 2002). That's why we focused on complex development of logistics and information technology.

The real capacities for forming effective logistic chains using cutting-edge information technologies should be compared to the integral effect of their implementation (Sarraaj et al., 2014). It is also necessary to consider the studies on the formation of variable-based scenarios of intermodal transportation (Pekin et al., 2013) as the basis for decision-making in regards to the route and transport (Lehtinen & Bask Anu, 2012).

The Monte Carlo simulation model should be used to assess the breakeven and formation of an effective strategy (Kim & Van Wee, 2011). The integrational

probability model enables forming a railroad network matrix and the rout flowchart, and detecting bottlenecks (Winkler & Kuss, 2016).

The analysis of the strategy for the development of rail transport in Kazakhstan found an active development of intermodal transportation, which requires integration of various types of software and information support. Such dynamic can be provided by cloud technologies, for instance, web-based solutions that use railway e Maintenance (Kour et al., 2014; Kour, Tretten & Karim, 2014). The electronic messages regarding the flow of route documents can be formed in a similar fashion.

Information technologies are developed rapidly and implemented comprehensively in all areas of the transport industry (Liden, 2015); this is possible only within a structure of global intelligent transport systems, which covers all technological processes and includes versatile and easy-to-use hi-tech repairs equipment that prevents rolling stock delays (Gnatov & Argun, 2015).

The analysis of experience in the implementation of electronic support of transport operations in various countries, for instance, Turkey and Finland [29, 30] shows that the strategy for the informatization of Kazakhstan's transport system and the formation of standalone AW should take into consideration the international trends in the development of information and management technologies and integration of various information systems into a unified complex.

The second research area uses the tools of operation studies, which enables mathematically formulating the complex problems of intermodal rail transport (Kim & Van Wee, 2011; Winkler & Kuss, 2016) and using various software to model, monitor, and manage functional processes (Gorman, 2015).

Aim of the Study

The research aims at using the synergetic approach to creating an automated workstation for rail transport specialists by the example of a freight cashier AW.

Research questions

The research questions were as follows:

What are the conceptual approaches to the formation of the complex automated rail transport system? Which approach best suits the creation of an automated workstation of a freight cashier?

Method

To develop the concept of a computer workstation of a freight officer, the historical examples of development of an automated railway transport management system and current trends of cloud technologies have been analyzed.

An overall composition of intelligent information transport system has been created with graphical modeling. This composition is the basis for the development of a network of computer workstations. Among them the authors identified the computer workstation of a freight officer.

The models of technology processes and algorithms for their implementation have been developed using the methods of observation and application of photo chronometry to labor process. The basis for this method is photography of worker's actions per shift with simultaneous supervision of stopwatch study upon the

duration of his actions. The collected materials for a long time of commercial employee actions have been processed. Formalization of the processes is carried out with the help of visual diagrams, which can further be used to optimize them.

The mathematical apparatus of research, calculation and optimization of logical systems is a simulation pertaining to the theory of probability, mathematical statistics and represented in terms of queuing theory (Khusainova, Shilova & Curteva, 2016). The algorithm flowchart of activities of freight officers is formed in the paper.

Data, Analysis, and Results

Automated workstation

Automated workstations of rail transport specialists $AW_1, AW_2, AW_3 \dots AW_n$ should be integrated into a single complex intelligent transport information system that covers all technological processes (Figure 1).

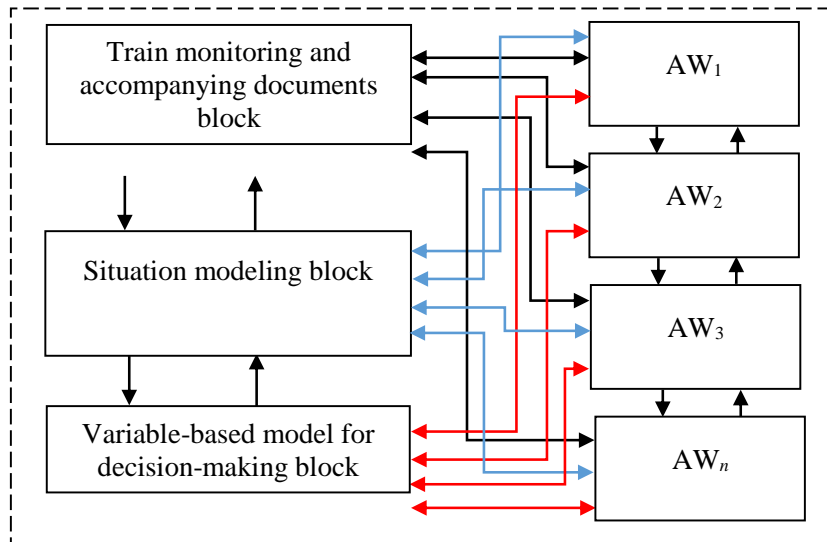

Figure 1. Flowchart of an intelligent transport information system

Despite the fact that information system vendors offer ready-to-use solutions for the implementation of AWs, considerable effort is required to systematize the technological processes, develop a general concept of transportation automation and information support. The implementation of AWs will cut the time required to search for and process information, improve the quality and speed of service delivery, provide for dynamic monitoring of changes, minimize the device failure rate, reduce the percentage of paper documents in use, and reduce the risk of making erroneous decisions.

Intelligent transport system model

Integrated intelligent transport systems shall address such basic tasks:

1. Management of transportations by operators of railway transport.
2. Automation of operational forecasting.
3. Ensuring safety in operation.
4. Information security.
5. Information support of decision-making.

6. Electronic payments.
7. Information support of forwarders.
8. Information support of travelers.
9. Automated control systems of vehicles.

Let us consider the basic properties of computer workstation as a component of an integrated intelligent transport system.

1. Integrity. Information space of a computer workstation of a railway specialist shall contain functional units of automation of technological processes, have the tools of interaction between all participants of a process, especially the owners of the previous and subsequent processes. Strategic documents, the overall concept and the map of logistical operations, the possibility of simulations and dynamic hints for decision-making shall be also formed according to the accepted rules and situations in the system of rail transport logistics.

2. Dynamism. The ability to make changes is based on the active use of network technologies and is controlled by an introduced security system and multi-level access to the information.

3. Self-learning of a system. Monitoring processes and document flow, the work of analysts group allows to create basic situational models of activity of railway transport specialists, performance of equipment, instructions, hints for decision-making in difficult situations. This database is constantly updated, used for training and self-training of personnel.

4. Automatic generating of the routing report is made using geographic information system (GIS) unit. The routing points, matching time of delivery, the cargo parameters, etc. are marked in the unit.

5. Computer workstation information is visualized using the representation of railway maps, process models, documents, printing certain documents.

The perfect system is the introduction of quality management system of transport services. International ISP/TR standards describe the method of creating the architecture of intelligent information systems and recommend to use process modeling using UML (Xing-cai et al., 2014). This system provides for description and modeling of all technological processes, the defining of owners and process participants, risks of force majeure, the quality parameters of transport services.

Preparation for the introduction of intelligent quality system shall optimize all the processes of the transport company and to detail all functional and documented processes for each computer workstation. Among the key parameters of quality of transport service one can allocate time from order acceptance for transportation to delivery; reliability and ability to deliver the goods; completeness and availability of the order performance; convenience of placing and confirming the order.

Intelligent transport information system is built regarding three main objects - the sender, the recipient, the executive of transportation services. It is the visual logistical chain with specific nodes of documents passing, identified operation risk nodes in order to reduce them to a minimum. International ISO standards are complemented by the approved requirements of consumers of transport services and features of the national transport system – the participants of logistical chain.

Figure 2 shows the developed intelligent transport system model.

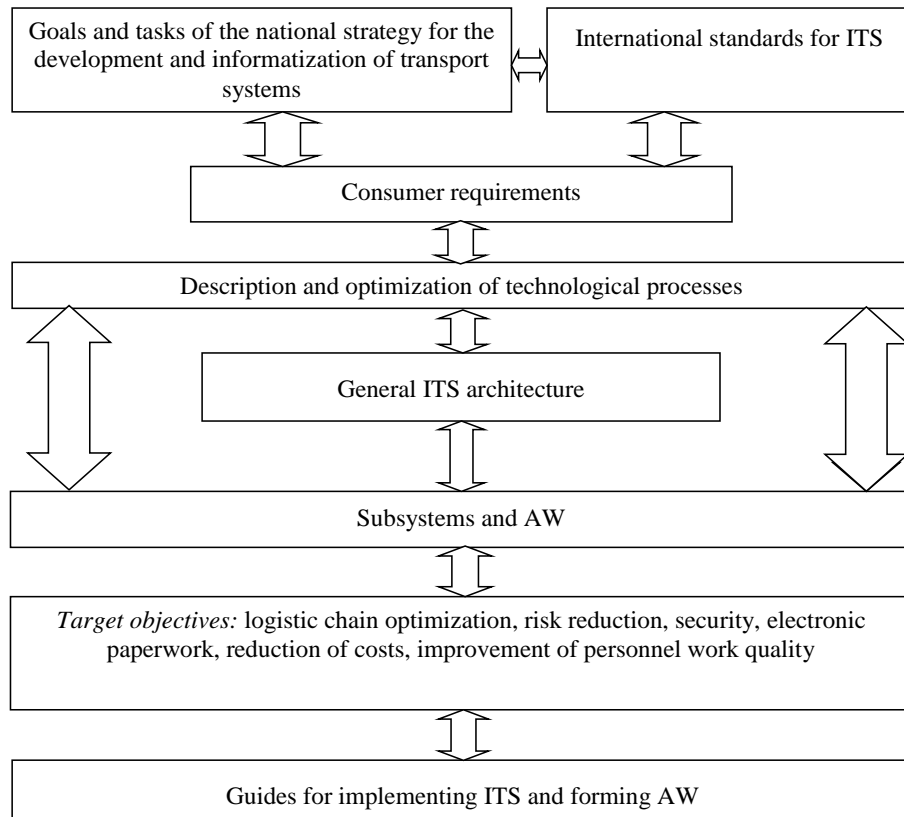

Figure 2. Intelligent transport system model

Computer workstation of a specialist is the unit of a single information transport space in which the transport units and documents are predictable objects. Analytical units of computer workstation allow to forecast the route, personnel actions, to simulate different situations.

This model is the basis for a synergetic approach to the development or upgrading of a computer workstation of a railway specialist. The essence of this approach is to form an effective information space with the target transport service features and abilities for self-training and self-analysis. This can be implemented with the use of description of existing processes and results of learning the international standards, international experience of performing certain procedures and monitoring supply chains in the transport network. Synergy of IITS development strategy and of each individual computer workstation, constant monitoring of the relationships between the target tactical and strategic objectives of improving the quality of transport services leads to development of an effective intelligent information system as a whole.

The implementation of such an architecture is possible only with a balance of three components:

- strategy and algorithms of management, organizational support;
- technical facilities – special hardware and software;
- effective system of personnel training and motivation.

The system works on the principle of the "two mirrors" (Kovalenko, 2012). That is, on the one hand, an intelligent transport system reflects all active processes. On the other hand, it predicts the processes for a specific logistical chain. Development of the visual interface is implemented by means of a detailed survey of owners and participants of processes with further modeling and optimization. In the international standards of telematics systems the definitions "intelligent cargo", "intelligent cargo technologies" are determined (Skalozub et al., 2013). The focus is made on the automatic collection of traffic conditions data, process modeling, forecast of emergencies, automatic generation and updating documents.

Another theoretical and practical area is the security, reduction of probability of threats such as unauthorized access to the administration and data, and information leak. AWs should have tools to visualize dynamic diagnostic messages and access to the database of target objectives. It is expedient to introduce a new definition of "intelligent automated workstation", which, besides the automation of target functions, will manage intelligent loads using cutting-edge visual information technologies.

Optimizing the processes of a freight cashier's work

The existing ways of studying the costs of working time and their derived possibilities for assessing the load of a freight cashier were analyzed based on the investigation of the activity of railway transport workers.

The analysis found that the most reasonable research method was work time study, which is based on photographing the actions of a working during a shift combined with chronometric monitoring of the duration of this or that action. The treatment of the material collected over an extensive period of work showed that the workers' actions consisted of basic tasks aimed at preparing a set of carriage documents, calculating payments for carriage, receiving acceptance operator records, checking, managing, and taxing car supply and cleaning cards, management of supplementary fee cards and record cards (for freight storage, wash, carriage cleaning, etc.), compilation of reports on carriage delays, delivery of money to bill collectors, cashbook keeping, re-shipping, issuance of various certificates, keeping and issuance of forwarding cards, etc. (Kovalenko, 2012).

The statistical data for the analysis of the freight cashiers' work can be determined through monitoring or analytically – by using known correlations of the theory of probability and mass service.

Consider an example – a logical algorithm scheme (LAS) of freight cashiers for the solution of an "Assessment and Forecast of Status in a Freight Office" commercial problem:

$$PK_{o.p.} = D_1 M_1 P_1 A_1 D_2 R_1 / D_3 R_2 F_1 A_2 R_3 / D_4 R_4 / D_5 R_2 D_6 R_5 F_2 D_7 R_6 F_3 F_4 D_8 \quad (1)$$

M1P1 – check departure station plan;

A1 – analysis of data obtained;

D2 – tick rating;

R1 – registry of actual network prohibitions and restrictions of goods acceptance to transportation;

D3 – check consignor's seal on-hand;

R2 – railway bill validation;



F1 – computer data entry of available difficulties caused by breakdown/failure;

A2 – situation status analysis;

R3 – agree on expected dimensions and TOT (time of transmission) by adjacent wayside stations;

D4 – adjacent wayside station calls;

R4 – assign a dispatch number;

D5P2 – report to senior freight officer of possible difficulties and get recommendations of regulating measures;

D6 – calls with area chief rail traffic controller and SDO (station duty officer) of junction stations of on-site job progress;

R5 – on-site job difficulties on hand or expected;

F2 – enter possible on-site job difficulties;

D7 – writing out an f. KEU-16 order etc.;

R6 – unserviceable locomotives on hand;

F3 – enter data of unserviceable locomotives;

F4 – computer entry of adjusted forecast;

D8 – sending by SDO (Station Duty Officer) general recommendations of next jobs ahead.

The following is a logical chain of operations during the solution of an “Assessment and Forecast of Status at the Freight Cash Desk”:

$$KZ_1 = D_1 F_1 P_1 F_2 R_1 / F_3 / P_2 V G_1 F_4 / P_3 / A_1 F_5 / C_1 V C_1 R_4 / A_2 F_6 / D_3 R_5 / F_7 / O_1 D_4 \quad (2)$$

where D1 – check consignor’s paying capacity;

F1 – fill in the accountancy documents with consignor’s details;

P1 – receive reports from acceptance/delivery agents and operator and other executives of device statuses and incomplete arrangement of personnel;

F2 – enter data of device statuses and incomplete arrangement of personnel;

R1 – device malfunctions and incomplete arrangement of personnel on-hand;

F3 – enter this data;

P2 – documents for lost cargo available;

VG1 – assessment and choice of input method of cargo data in shipping documents;

F4 – enter chosen method;

R3 – supposed violation of team jobs regime;

A1 – analysis of data available;

F5 – enter supposed violation;

S1 – calculate overall magnitude of situation;

VS1 – comparative assessment of actual situation at the station and processing documents;

R4 – supposed on-site job difficulties;

A2 – analysis of data obtained;

F6 – enter difficulty;

D3 – calls with locomotive dispatcher of serviceable locomotives;

R5 – unserviceable locomotives on-hand;

F7 – enter this data;

O1 – overall assessment of the forecasted situation on junction;

D4 – calls and recommendations to executives of next jobs ahead.

Based on the LAS, it is possible to write down a formula for calculating the duration of the operative problem solution:

$$T_{oz} = t_{D_1} + t_{M_1P_1} + t_{A_1} + t_{D_2} + R_1(t_{D_3}) + R_2(t_{F_1} + t_{A_2}) + R_3(t_{D_4}) + R_4(t_{D_5P_2} + t_{D_6}) + R_5(t_{F_2}) + t_{D_7} + R_6(t_{F_3}) + t_{F_4} + t_{D_8}, \quad (3)$$

where t_{D_1} , $t_{M_1P_1}$, t_{A_1} , t_{D_2} etc. – duration of processing one elementary operation, min.

Loading solution for an operational problem is calculated according to the formula:

$$t_{on} = N \cdot \sum_{i=1}^n (t_i \cdot P_i), \quad (4)$$

where: N - number of documents processed per shift;

n - number of business problems being solved;

t_i - duration of solving business problems, min;

P_i - frequency of management problem occurrence or probability of condition occurrence which need the problem solution.

Figure 3 shows a flowchart and a block diagram for activity algorithms of a freight officer when solving management problems.

The duration of solving operational problems, as it follows from the analysis of algorithms, can vary depending on the equipment at workstations, information support, the number and duration of elementary operations, the statistical characteristics of elementary operations, determination of mathematical expectation, variance, standard deviation and variations of solution duration of each elementary operation (bill - t_c , calls – t_D , data search - t_s , enter results - t_F , information extraction from memory - t_e , comparison - t_n etc.).

The probability of occurrence of relevant situations can be determined from statistical data obtained from observations of personnel actions.

These probabilities are defined in (Berikbayev & Isina, 2005), but not all possible situations have been analyzed, and the number of situations analyzed made possible to determine only approximate probability. The probability of the outcomes of logical conditions $P(A)$ considered in solving operational problems can be the probability of the sum of joint events:

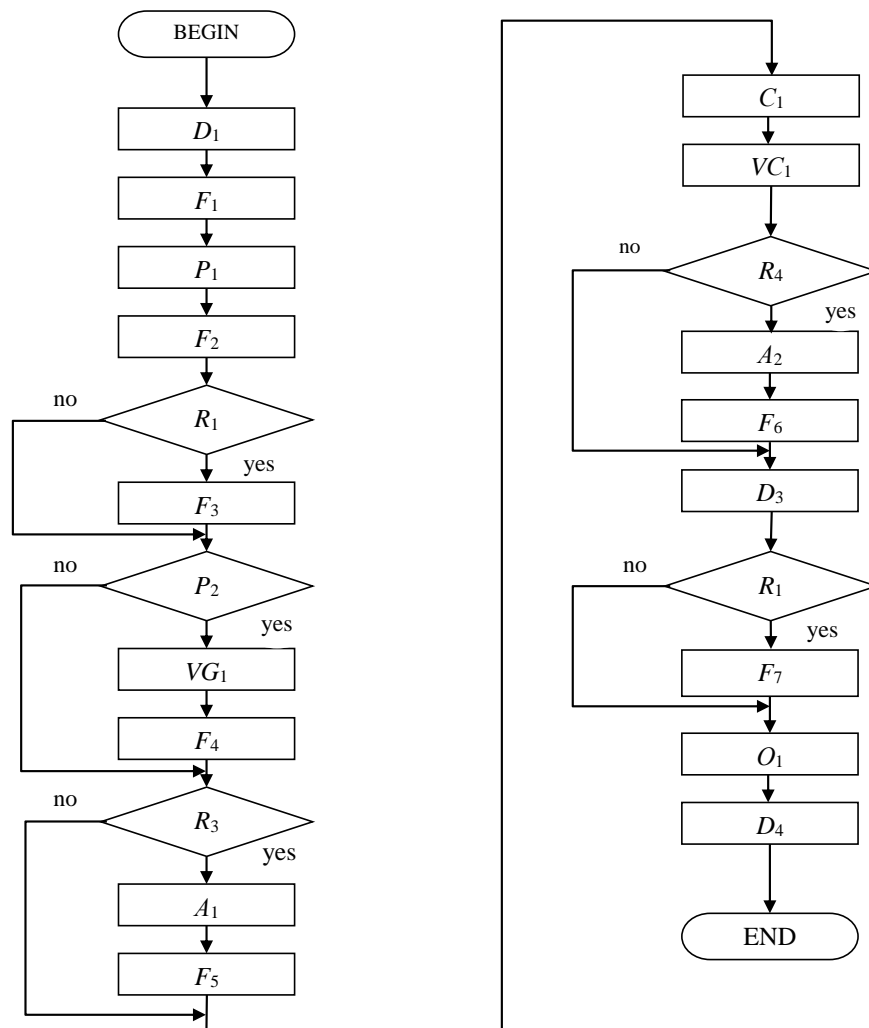

Figure 3. Block diagram of a business problem "Estimation and forecast of situation in freight office" compiled according to the algorithm.

Duration of solving business problems, as it follows from the analysis of algorithms, can vary depending on technical equipment at workstations, information support of a freight officer, the number of processed documents, as well as the number of clients served, and the duration of elementary operations (Table 1).

$$P\left(\sum_{i=1}^n A_i\right) = \sum_i P(A_i) - \sum_{ij} P(A_i A_j) + \sum_{ijk} P(A_i A_j A_k) - \dots + (-1)^{n-1} P(A_1 A_2 \dots A_n) \quad (5)$$

Table 1. Elementary operations performed by a freight officer and their duration

S.R. No.	Elementary operations	Duration
1	Shift turnover	09.00-09.30
2	Report to division superintendent	09.30-10.15
3	Mail separation	10.15-11.00
4	Give oral information	11.00-11.15
5	Prepare documents for cargos dispatch to Chelyabinsk	11.15-12.35
6	Calls regarding the cargo from Almaty and from Karaganda	12.35-13.00
7	Lunchtime	13.00-14.00
8	Prepare documents for recipients	14.00-15.20
9	Letter and calls to Karaganda regarding the lost cargo	15.20-15.50
10	Give written information	15.50-16.05
11	Solve issues of cargo receipt by the individuals	16.05-16.35
12	Letter regarding the cargo, written reply receipt	16.35-16.55
13	Explain the issues regarding the cargo from Bishkek	16.55-17.10
14	Find proofs that he must pay more	17.10-17.50
15	Compose a letter containing proofs he was wrong	17.50-18.05
16	Calls to forwarding agent	18.05-18.20
17	Compose Power of Attorney	18.20-18.30
18	Receive rate quotation	18.30-18.45
19	Track the client's cargo	18.45-19.00
20	Calls to suppliers	19.00-19.15
21	Reply to a letter, send instructions on cargo dispatch	19.15-19.45
22	Check mail, reply all inquiries	19.45-20.00
23	Reply to the client's letter regarding his cargo transportation from Sayak to Karaganda	20.00-20.20
24	Inquiry from Pavlodar for customs clearance and TD-PRO pricing	20.20-20.40
25	Shift turnover	20.40-21.00

The authors have sampled observation materials of the work of a freight officer for 15 shifts. As a result, they have set the duration of shipping documents preparation, the scope of work, calls, repairs and cases of deviation in their work, leisure duration and other data for the calculation summarized in Table 2.

Table 2. Data necessary to calculate the probability of logical conditions

S.R. No.	Operations	#
1	Compose transportation documents for cargos acceptance/delivery, for all fees and penalties	62
2	Compose a document at computer workstation of a freight officer	32
3	Keep Accounting and Reporting books	38
4	Check correct filling of transportation documents submitted by consignors	2
5	Documents acceptance and delivery to loaded and ongoing unloaded cargos	2
6	Charge and recover due payments from consignees and consignors in favor of railways; no loan receivables allowed	1
7	Daily reconciliation of funds of consignees and consignors with Technology Center for carriage document processing	11
8	Accounting of consignees' and consignors' funds availability	27
9	Issue client cards for charging fees and penalties	39
10	Verify upon cargo arrival the amounts being recovered on dispatch; exact all additional amounts appeared before issuance of railway bill	5



Table 2. (continued)

11	Charge fees, penalties for car detention, storing cargos according to car supply and cleaning acts, acts of general form, etc.	15
12	Send documents to Technology Center for carriage document processing	88
13	Make out bank slips forms GU-57, MD-4	14
14	Compose income report per day	2
15	Check and register consignees' 4-digit rail code, OKPO (RNNBO - Russian National Nomenclature of Businesses and Organizations) code, test protocol for knowledge of carriage rolling Load and Safety Specifications, 4-digit consignee code within cargo dispatch	8
16	Compose customs invoices. Data records to registry of customs invoices	12
17	Compose station commercial accounts if funds of consignees, consignors, forwarding companies available in Technology Center for carriage document processing; no loan receivables allowed	14
18	Timely notification of customs authorities of customs cargo arrivals. Issue documents for customs clearance by customs inspector. Check documents after customs clearance	2
19	Notify transport veterinarian of arrival and submission of cargos undergoing state compulsory veterinary, phytosanitary inspection on import, export and domestic transportations	3
20	Timely send messages 410, 406, 253 via computer workstation of a freight officer	2
21	Transfer load/unload report according to GO-1, GO-2 forms	6
22	Tariffs and services for cargo transportations being paid by consignors and consignees with transportations cards	3

Thus, the components of the "complex" for freight and commercial jobs management shall be considered as a probabilistic system. It includes the incoming flow, the totality of emerging operational problems for freight and commercial jobs management. These problems can be solved using organizational and technological complex for receiving, processing and transmitting information (Figure 4).

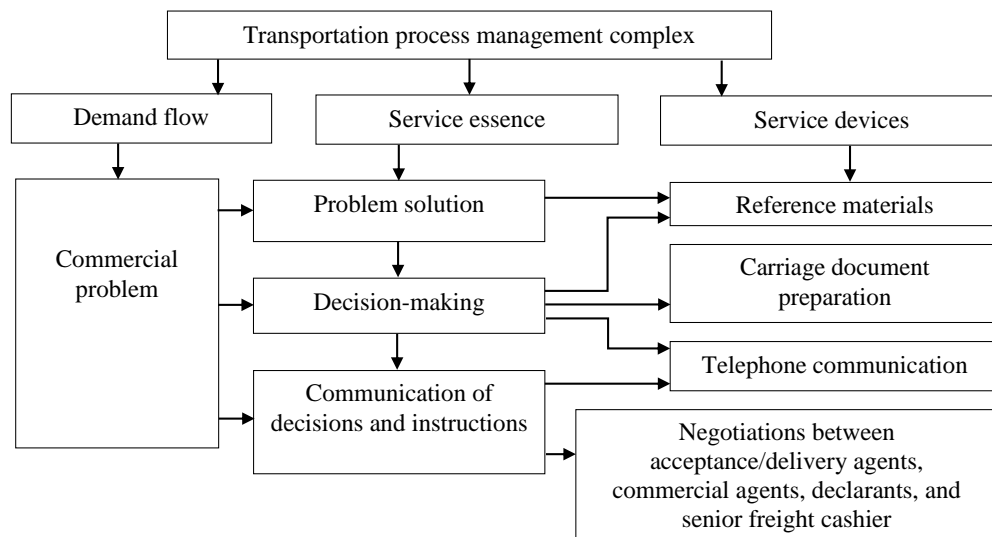

Figure 4. Transportation process management complex

Figure 5 shows the modernized components of the transportation process management complex.

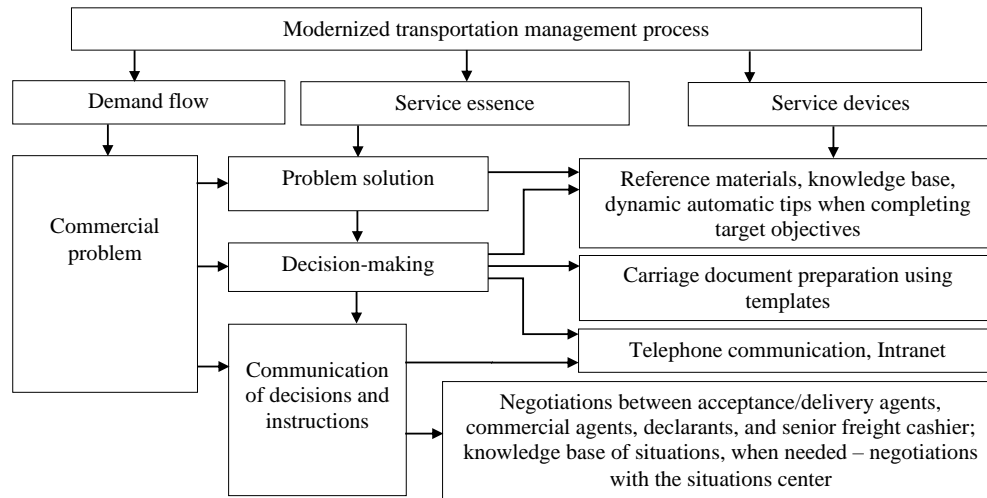

Figure 5. Modernized transportation process management complex

Traditionally, reference materials and talkback technology have been used. Now, for a specialist in the integrated intelligent system, visual hints as short text are automatically formed, patterns of all documents have been generated, auto-messages which reduce the risk of non-targeted operations are generated. Besides, the situation knowledge base of the activity of a particular specialist in transportation process allows a quick decision-making or, if necessary, contacting the situation room.

Establishment of analytical relationships for determining the values of the flow parameters is very important to solve the problem. It is particularly important to set the value of the variation coefficient. It depends on the values of variation coefficients of incoming flow and the duration of service, as far as on the service system load.

Discussion and Conclusion

The experience of Russian Railways specialists shows that the level of automation of Russian Railways JSC is 20% of the total number of technological processes, which indicates the need for improving information systems (Skalozub et al., 2013; Connolly, 2014).

Various approaches and methods are used to optimize transportation. Most of them are interesting and promising for wide use. For instance, research (Rosová, Balog & Šimeková, 2013) offers an approach for reducing the tractive power energy by optimizing the operation of trains, which is undoubtedly interesting, but since this offer is limited to metro systems, the scope of its application is limited, as well.

The same flaw is inherent in the network model, transport model, and algorithms of linear programming, which are used to model the city system of rail transport in Nigeria (Agarana, Anake & Okagbue, 2016).

It is worth mentioning the promising method of optimization and integration for railway freight stations, based on a hybrid model of a neural network, suggested by the authors of research (Sun, Lang & Wang, 2014). However, this

development is not a finished solution of the problem and is currently being designed.

The proposed synergetic approach is simple to implement and more versatile, since combines the strategy of intelligent information systems development and the formation of computer workstations of railway transport specialists based on the use of modern management and information technologies, theories and queuing operations and process simulation algorithms. Given a large number of multidirectional scientific and practical studies in the field of introduction of information technology in the world transport systems, the authors propose to focus on intermodal transportation with intelligent information support. It is implemented by means of modern intelligent systems and advanced computer workstations. The proposed definition of an intelligent computer workstation expands the international standard of modern information transport technologies.

Intelligent computer workstation is not only the introduction of automated targeted processes, but also the elements of artificial intelligence to forecast situations and decision-making. This approach allows taking into account the peculiarities of each process, adapting it to the overall strategy and tactics of the implementation of transport services, and traffic safety support. It allows the creating a comfortable information space in order to perform routine tasks and decision-making.

Computer workstation of a freight officer has been chosen by the authors as an example of implementation. It is the closest related to the procedures for informing customers about cargo status. It requires modernization taking into account the active development of cloud computing, Internet- and Intranet-monitoring systems, managing interactions with customers.

In many countries the problem of an integrated information system of automation of transport processes has not been fully solved. This has been shown by data analysis of practical introduction of computer workstation of a freight officer. For example, Slovakia started introducing the electronic waybills [1]. However, from the study materials the relationship of technology processes and monitoring systems of commodity transactions is not entirely clear. In the United States, Canada, Australia, the European Union, the former Soviet Union countries the introduction processes based on SAP system have intensified (Rosová, Balog & Šimeková, 2013; Huang et al., 2015; Agarana, Anake & Okagbue, 2016; Sun, Lang & Wang, 2014; Connolly, 2014). This system implies the use of information and analytical units of electronic waybills, development of a single information transport space. However, it is quite expensive both to introduce and to operate.

At the same time, the choice of a vendor to implement an intelligent information transport system, modernization of the existing computer workstations shall be reasonable. The choice shall consider all the opportunities, threats and risks, resources, further development of railway sector and certainly the human factor - convenience and unloading the owners and executives of routine processes. The issue of integration of an intelligent transport system with quality management tools of transport services has not been completely solved, too, and requires a separate study.

To sum up, the introduction and modernization of the computer workstations of railway transport specialists most effectively can be implemented in a single transport information space. The space provides the development of "intelligent

transport architecture", in the center of which there are users of transport services in accordance with national and international security interests and development of transport networks.

Intelligent transport systems provide the creation of such an information space, include telecommunication networks, automatic identification systems, systems for the detection and tracking of vehicles, protocols for electronic data exchange, cartographic knowledge base and geographic information systems, simulation technology processes, service system for users, information support system for decision-making, computer workstations of process owners.

Detailing and formalization of computer workstation of a freight officer allows optimizing the basic algorithms and procedures of activities of a freight officer and building an effective information space to perform targeted functions.

Implications and Recommendations

On the example of this computer workstation, computer stations of specialists from other areas can be upgraded further, focusing on forecasting different situations under uncertainty.

Further studies can detail such areas as economic and mathematical modeling of logistical processes; evaluation of computer workstations and information systems in transport infrastructure, methods of teaching personnel at the enterprises of railway transport.

Disclosure statement

No potential conflict of interest was reported by the authors.

Notes on contributors

Saken K. Malybaev Doctor of Engineering, Professor of Industrial Vehicles Department, Karaganda State Technical University, Karaganda, Kazakhstan;

Nurlan S. Malaybaev holds a PhD, Associate Professor of Industrial Vehicles Department, Karaganda State Technical University, Karaganda, Kazakhstan;

Botakoz M. Isina Master, Senior Lecturer of Industrial Vehicles Department, Karaganda State Technical University, Karaganda, Kazakhstan;

Akbope R. Kenzhekeeva Master, Senior Lecturer of Industrial Vehicles Department, Karaganda State Technical University, Karaganda, Kazakhstan;

Nurbol Khuangan holds a PhD, Associate Professor of Industrial Vehicles Department, Karaganda State Technical University, Karaganda, Kazakhstan.

References

- Agarana, M., Anake, T. & Okagbue, H. (2016). Optimization of Urban Rail Transportation in Emerging Countries Using Operational Research Techniques. *Applied Mathematics*, 7, 1116-1123. <http://dx.doi.org/10.4236/am.2016.710099>
- Balog, M. et al. (2015). Automation Monitoring of Railway Transit by Using Rfid Technology. *Acta Technologia - International Scientific Journal about Technologies*, 1(1), 9-12.
- Banister, D. & Stead, D. (2004). Impact of information and communications technology on transport. *Transport Reviews*, 24(5), 611-632.
- Berikbayev, N. & Isina, B. (2005). Improving the operation of a freight office. *Magistral*, 2005(6), 78-80.
- Connolly, B. (2014). Australian rail firm in SAP first Aurizon begins deploying freight system based on SAP supply chain platform. http://www.cio.com.au/article/535718/australian_rail_firm_sap_first/



- Gnatov, A. & Argun, Sch. (2015). New Method of Car Body Panel External Straightening: Tools of Method. *International Journal of Vehicular Technology*, 2015, 1-7. doi:10.1155/2015/192958
- Gorman, F. (2015). *Handbook of Operations Research Applications at Railroads, International Series in Operations Research & Management Science Springer Vol. 222*. Operations Research in Rail Pricing and Revenue Management. New York: Springer Science + Business Media.
- Hitachi Data Systems (2012). Hitachi Converged Solution Brings Virtualization and Top Performance to Russian Railways. Santa Clara: HDS. <https://www.hds.com/assets/pdf/hitachi-success-story-russian-railways.pdf>
- Huang, Y. et al. (2015). Optimization of Train Operation in Multiple Interstations with Multi-Population Genetic Algorithm. *Energies*, 8, 14311-14329.
- Inkinen, T., Tapaninen, U. & Pulli, H. (2009). Electronic information transfer in a transport chain. *Industrial Management & Data Systems*, 109(6), 809 – 824.
- Khusainova, R., Shilova, Z., & Curteva, O. (2016). Selection of Appropriate Statistical Methods for Research Results Processing. *Mathematics Education*, 11(1), 303-315.
- Kim, N. & Van Wee, B. (2011). The relative importance of factors that influence the break-even distance of intermodal freight transport systems. *Journal of transport geography*, 19(4), 859-875.
- Kour, R. et al. (2014). Applications of radio frequency identification (RFID) technology with eMaintenance cloud for railway system. *International Journal of Systems Assurance Engineering and Management*, 5(1), 99–106.
- Kour, R., Tretten, P. & Karim, R. (2014). eMaintenance solution through online data analysis for railway maintenance decision-making. *Journal of Quality in Maintenance Engineering*, 20(3), 262 – 275.
- Kovalenko, Ye. (2012). The methodology of designing organization information systems – the double-mirror concept. *Russian Academic Journal*, 2012(4), 38-41.
- Lehtinen, J. & Bask Anu, H. (2012). Analysis of business models for potential 3Mode transport corridor. *Journal of Transport Geography*, 22, P. 96-108.
- Liden, T. (2015). Railway infrastructure maintenance - a survey of planning problems and conducted research. *Transportation Research Procedia*, 10, 574–583.
- Lietuvos Geležinkeliai (2014). Information Technology Lietuvos Geležinkeliai Annual Report. Vilnius: AB Lietuvos Geležinkeliai. http://www.litrail.lt/documents/10291/1488090/LG_2014_GB.pdf/e4462df0-04d3-4c17-86ba-2c14187fe923
- Overby, S. (2016). How IT is Helping the Railroad Industry Improve Efficiency and Service <http://www.cio.com/article/2433741/it-organization/how-it-is-helping-the-railroad-industry-improve-efficiency-and-service.html>
- Pekin, E. et al. (2013). Location Analysis Model for Belgian Intermodal Terminals: Importance of the value of time in the intermodal transport chain. *Computers in Industry*, 64(2), 113-120.
- Rabah, M. & Mahmassani, H. (2002). Impact of information and communication technologies on logistics and freight transportation – Example of vendor-managed inventories. *Freight Transportation*, 2002, 10-19.
- Rosová, A., Balog, M. & Šimeková, Ž. (2013). The use of the RFID in rail freight transport in the world as one of the new technologies of identification and communication. *Acta Montanistica Slovaca*, 18(1), 26-32.
- Saatçioğlu, Ö., Deveci, D. & Cerit, A. (2009). Logistics and transportation information systems in Turkey: e-government perspectives. *Transforming Government: People, Process and Policy*, 3(2), 144 – 162.
- SAP AG (2014). SAP Transportation Management 9.1 Overview of New Innovations for Release 9.1. Burlington: SAP. <http://a248.g.akamai.net/n/248/420835/f6beca0d9c07050282302395b97883900f8723a96aec95b37b8ff2a628bf3e6d/sapasset.download.akamai.com/420835/sapcom/docs/2015/08/c0f80686-5b7c-0010-82c7-eda71af511fa.pdf>
- Sarraj, R. et al. (2014). Analogies between Internet network and logistics service networks: challenges involved in the interconnection. *Journal of Intelligent Manufacturing*, 25(6), 1207-1219.
- Skalozub, V. et al. (2013). Intelligent transport systems of rail transport (information technology fundamentals). Dnipropetrovsk: V. Lazaryan Dnipropetrovsk National University of Railway Transport Publishing House.

- Smith, R. & Zhou, J. (2014). Background of recent developments of passenger railways in China, the UK and other European countries. *Journal of Zhejiang University Science A*, 15(12), 925–935. doi: 10.1631/jzus.a1400295
- Sun, Y., Lang, M. & Wang, D. (2014). Optimization and integration method for railway freight stations based on a hybrid neural network model. *Computer Modelling & New Technologies*, 18(11), 1233-1241
- Timofeev, A. (2015). The Rail Traffic Management with Usage of COTDR Monitoring Systems. In *Proceedings of 17th International Conference on Control, Automation and Robotics*. Zurich.
- UNECE (2012). *Intelligent Transport Systems (ITS) for sustainable mobility*. Geneva: UNECE.
- Winkler, H. & Kuss, C. (2016). *Sustainable Logistics and Strategic Transportation Planning*. Using a Supply Chain Improvement System (SCIS) to Increase Supply Chain Efficiency (Sustainable Logistics and Strategic Transportation Planning). Hershey: Business Science Reference.
- Xing-cai, L. et al. (2014). Synthetic Optimization Model and Algorithm for Railway Freight Center Station Location and Wagon Flow Organization Problem. *Mathematical Problems in Engineering*, 2014, 1-12. doi:10.1155/2014/